

AUTOMATION of POWER DISTRIBUTION

SUPREME & CO. PVT. LTD.

53, Justice Chandra Madhav Road, Kolkata - 700020. India.

Ph: 91-33-24748575 / 7565 | Fax: 91-33-2476-1955

Email: sales@supremeco.com | www.supremeco.com

AUTOMATION OF POWER DISTRIBUTION

BY

Gautam Agrarwal, Dharmbir Prasad & Santosh Kumar Singh.

Contact-engineeringteam@supreme.in

INTRODUCTION: Electric power utilities worldwide are increasingly adopting the computer aided monitoring, control and management of electric power distribution system to provide better services to electric consumers. The demand of reduced outage rates (both quality and duration) has led most electric companies to reconfigure their distribution networks from radial to normally opened looped, so once faulted section is isolated, power can be restored to the rest of the network from an alternative sources. This task is economically achieved by introducing distribution automation switches which are remotely controlled from a central control room. In this manner, quality and continuity of service to the customer are vastly improved as is user convenience. Therefore, the focus of electric research and development activities worldwide is to automate the electric power distribution system utilizing recent advancement in the area of Information Technology and data communication system.

NEED FOR DISTRIBUTION AUTOMATION

Due to lack of information at the base station (33KV substation) on the loading and health status of the 11KV/415V transformer with associated feeders is one of the primary causes of inefficient power distribution. Due to absence of monitoring, overloading occurs which result in low voltage at the customer end and increases the risk of frequent breakdown of transformers and feeders. In fact, the transformer breakdown rate in India is as high as around 20% in contrast to less than 2% in some advanced countries.

In the absence of switches at different points in the distribution network, it is not possible to isolate certain loads for load shedding as and when required. The only option available in the present distribution network is the circuit breaker (one each for every main 11KV feeder) at the 33KV substation. However, these circuit breakers are actually provided as a means of protection to completely isolate the down stream networks in the event of a fault. Using this as a tool for load management is not desirable, as it disconnects the power supply to a very large segment of consumers. Clearly, there is a need to put in place a system that can achieve a finer resolution in load management.

In the event of a fault in any feeder section downstream, the circuit breaker at the 33KV substation trips (opens). As a result there is a blackout over a large section of the distribution network. If the faulty feeder segment could be precisely identified, it would be possible to substantially reduce the blackout area, by re-routing the power to the healthy feeder segments through the operation of switches placed at strategic location in various feeder segments.

BENEFITS OF DISTRIBUTION AUTOMATION

- Reduce peak load and power losses to overcome prevailing power shortages and defer construction of distribution facilities.
- Improve the reliability of supply by reducing the number and duration of the outages and improve the quality of services.
- Improve the financial performance of the utility by improved cash flow, safeguarding revenues and prevent theft of power.

The Institute of Electrical and Electronic Engineers (IEEE) has defined Distribution Automation System (DAS) as “**a system that enables an electric utility to remotely monitor, coordinate and operate distribution components, in a real-time mode from remote locations**”. The distribution automation system is based on an integrated technology, which involves collecting data and analyzing information to make control decisions, implementing the appropriate control decisions in the field, and also verifying that the desired result is achieved. The location, from where control decisions are initiated, is generally called Distribution Control Centre (DCC). There are two key software elements – Master Distribution Automation Software and Engineering Analysis Software at the DCC. The master DA software acquires the system data (both static and dynamic) and converts it into an information system. The engineering analysis software provides the control decision utilizing the system information, available at the DCC. The decision making feature of the distribution automation distinguishes it from the normal Supervisory Control and Data Acquisition (SCADA) system. Power Distribution Automation is an emerging field in the area of electrical engineering.

Distribution Automation system is beneficial in day-to-day operation and maintenance of distribution network. The other benefits of the distribution automation are: reduced technical and commercial losses, improved cash flow, lower electric service restoration time, reduction in equipment damage, better availability of system information, improved operational planning, remote load control and shedding, and enhanced power quality and reliability.

Currently the scope of Power System Automation in India has been limited to SCADA system automation up to transmission level. However, as the figures given below indicate, the substations contribute only 1% of the outages. Hence the need for protection of the system beyond the substation becomes very important. As such the fledgling field of DAS in India will become extremely critical in the coming years.

Substations	Primary distribution circuits	Secondary distribution circuits
Less than 1% of outages	44% of outages	55% of outages
Contribute 5% to reliability	Contribute 87% to reliability	Contribute 8% to reliability

**Above data taken from EPRI Research Plan for Advanced Distribution Automation, 2005.

Intelligent Distribution Automation System

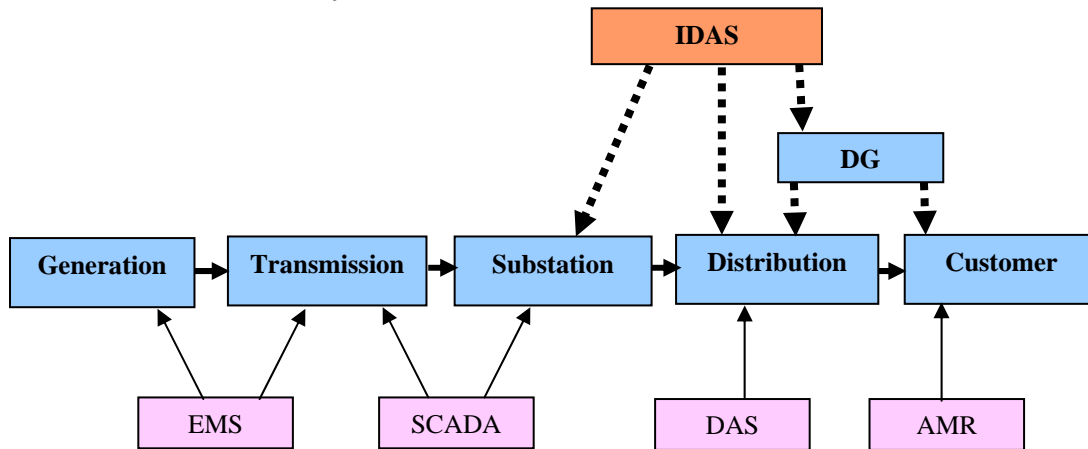

FUNCTIONAL CATEGORISATION OF DISTRIBUTION AUTOMATION

* Monitoring

* Control

* Protection

HIERARCHICAL AUTOMATION LEVELS OF DISTRIBUTION AUTOMATION

* Substation automation

* Feeder automation

* Customer or load automation

SCADA

A Supervisory Control and Data Acquisition (SCADA) system consists of one or more computers with appropriate applications software (Master Stations) connected by a communications system (wire, radio, power line carrier or fiber optics) to a number of remote terminal units (RTUs) placed at various locations to collect data and for remote control and to perform intelligent autonomous (local) control of a system and report results back to the remote master(s). The required control actions are then conveyed back to the process. The Concept of SCADA forms the basis of the DA System.

Utilization of SCADA in DA

Automatic generation control (AGC): Dispatch accuracy feedback, economic dispatch, energy purchased and sold, system load, system emulation, capacitor bank switching, monitoring voltage regulators, transformer temperature control

Fault identification: Isolation and service restoration breaker control, recloser blocking, feeder switching and reconfiguration, line switching, load management, automated meter reading (AMR)

The SCADA system consists

- Control Centre equipment
- Application software
- Distribution Management Software
- Communication System
- RTUs for field data acquisition
- UPS, etc.

SCADA Hardware

There are two main layers in a SCADA system:

Client Layers: These are responsible for the man machine interaction (MMI).

Data Server Layers: These are responsible for the process data control activities. The data servers communicate with devices in the field through process controllers (e.g. PLC) either directly or via networks or fieldbuses. Data servers are connected to each other and to client stations via an Ethernet LAN.

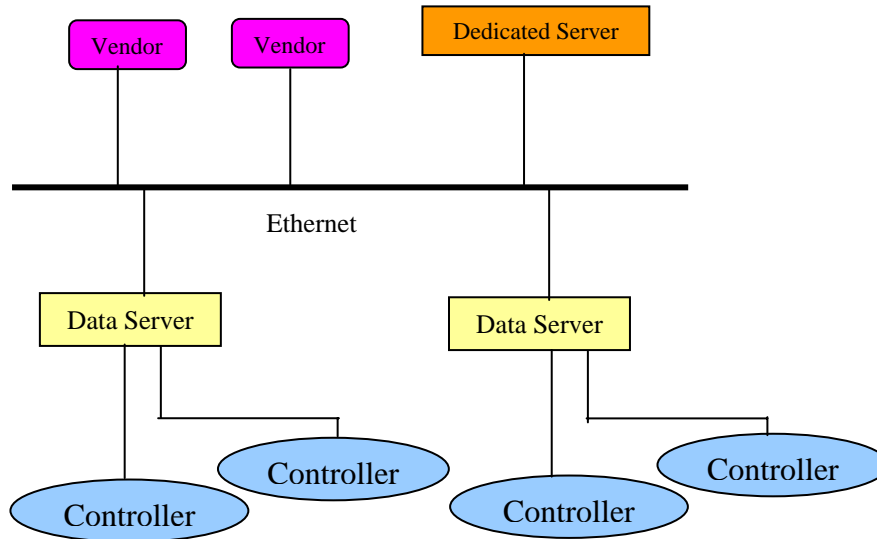

Fig: Typical Hardware Architecture

SCADA Software

Software located at different servers which help in real-time database analysis and multi-tasking such as data acquisition and controlling. SCADA software can be divided into two types, proprietary or open (e.g., Citect, Wonder Ware etc).

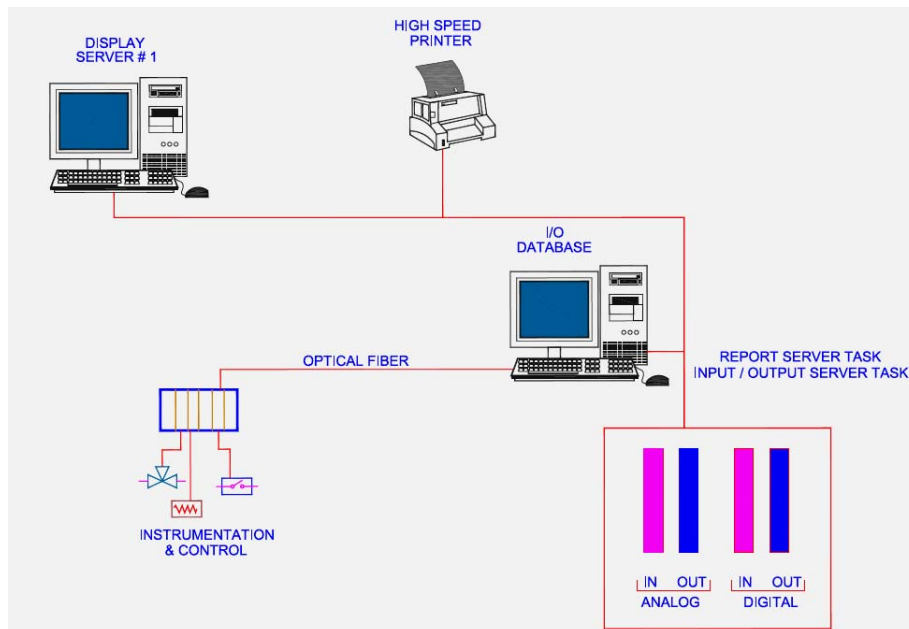

Fig: Typical SCADA System

RTU

An RTU is a microprocessor controlled device used to interface the various power system components and their operation to the DCC. It gathers local information and transmits it to the DCC and also accepts commands and logging requests sent to it by the DCC. Hence, the DCC can control and monitor the distribution networks by interfacing with the various RTUs. It has a capability to exchange the information with Intelligent Electronic Devices (IEDs) such as IED

meter and IED relays. RTU can support standard protocols (Modbus, IEC 60870-5-101/103/104, DNP3, IEC 61850, etc.) to interface any third party software.

Commercially, the RTU must be capable of performing the following functions:

- Collecting, Processing and Transmitting status changes, analog values and accumulator values.
- Receiving and processing digital and analog commands from the master station(s).
- Accepting polling messages from the master station(s).
- Supporting data transmission rates from 50 to 9600 bits per second
- Supporting up to 6 communication ports and multiple concurrent protocols, including the IEC 870-5-101 protocol.

The RTU hardware must be capable of supporting communication with multiple master stations, a local maintenance interface, and a local logger. As such, an RTU must have at least 4 communication ports.

- 2 Ports, Communication to DCC.
- 1 Port, Local Logger or Printer facility
- 1 Port, Maintenance Terminal.

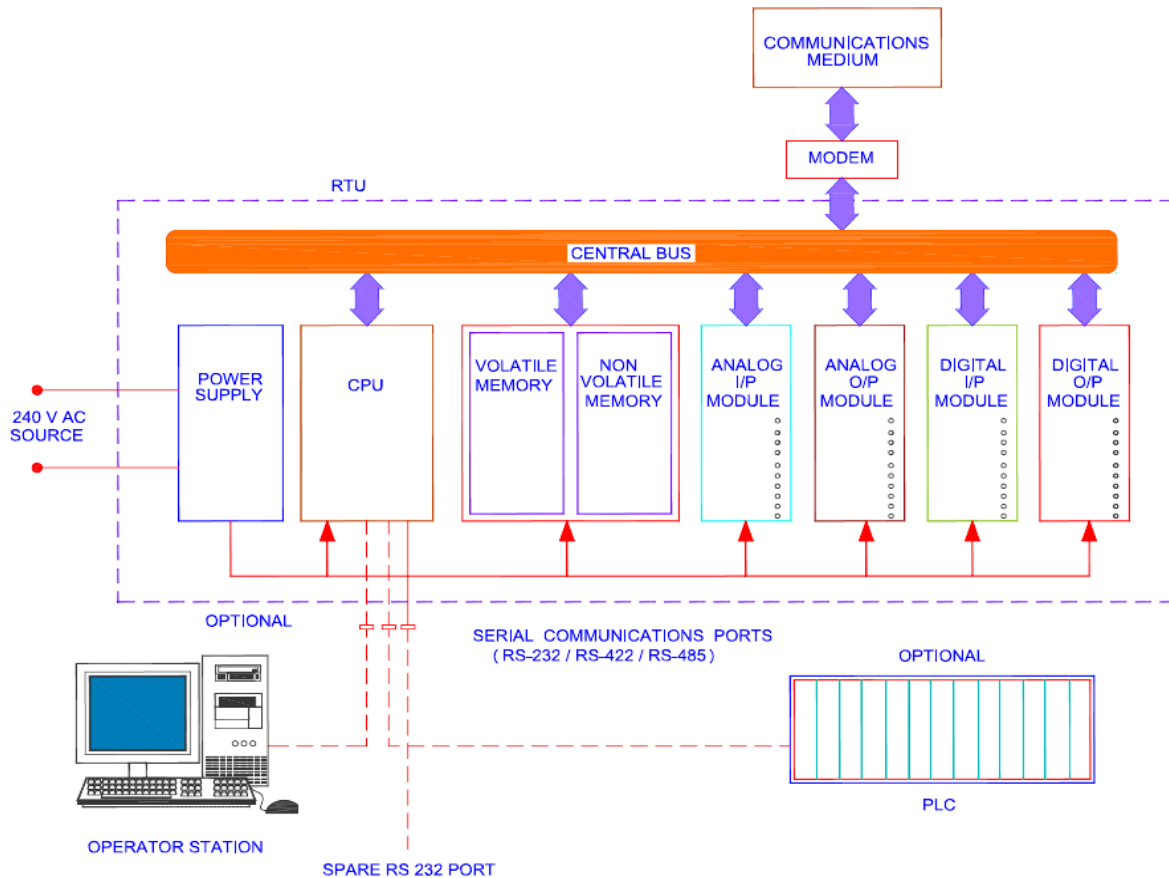

Fig: Typical RTU Hardware Structure

PLC Some of the important functions performed by PLC in Distribution Automation is as follows

- Used for the implementation of relays and control systems.
- Easy modification of software stored in EEPROM without undue changes to the existing hardware or core software.
- A PLC reporting to an RTU has many advantages over traditional RTUs in the field of closed loop PID control.
- Logic and PID control
- Operator control
- Energy savings
- Less maintenance and hence greater reliability

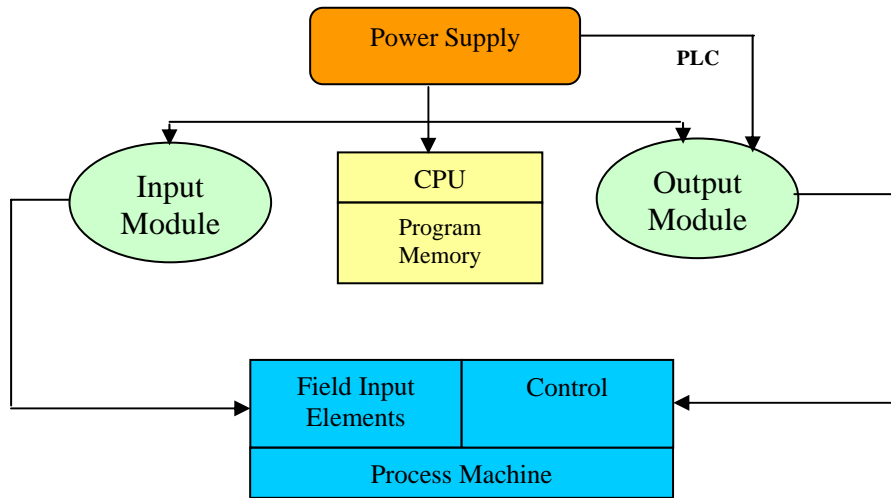
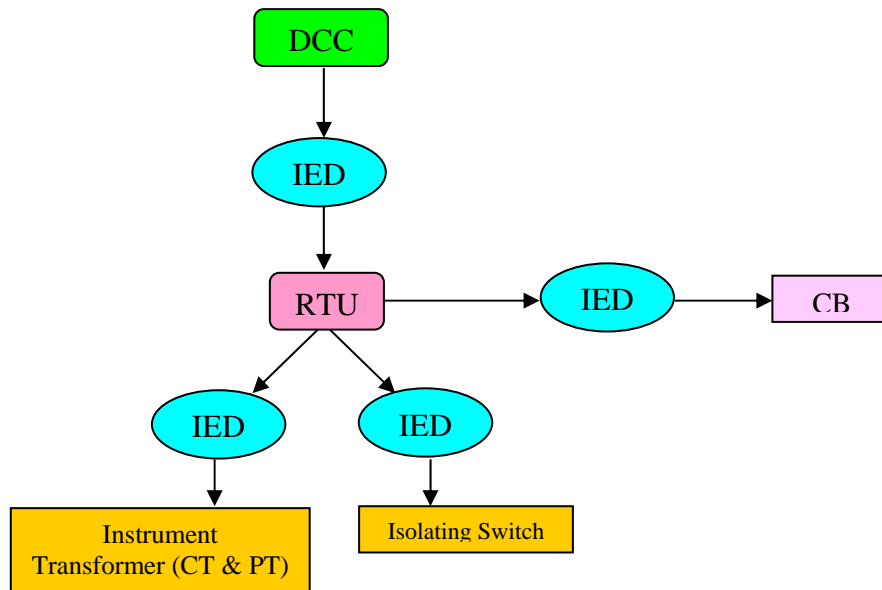

Fig: Block diagram of PLC System

IED

- It is a term used in the electric power Industry to describe microprocessor based controllers of power system equipment such as circuit breakers, relays, reclosers, voltage and var regulators, transformers, capacitor bank.
- IEDs are also substation host computers, RTUs, Programmable Logic Controllers (PLCs), time and frequency standards, communications processors, digital protective relays, sequence-of- events and fault recorders.



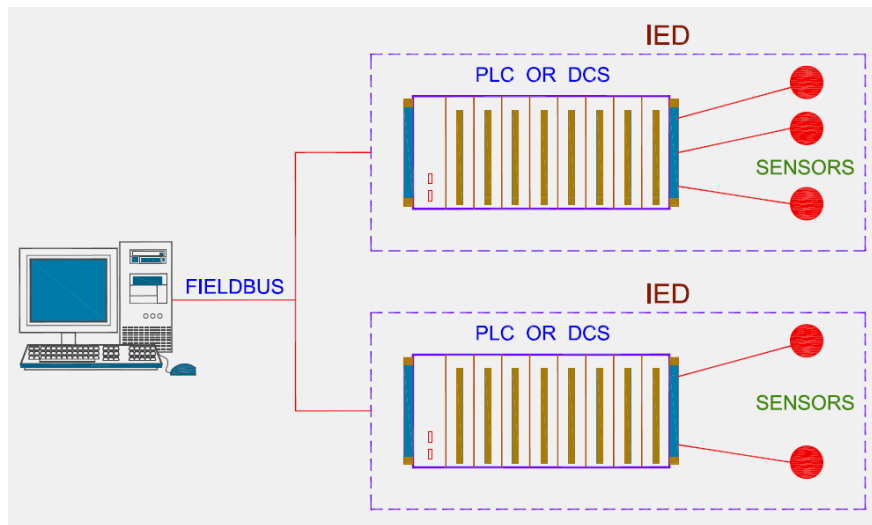

Fig: IED Connection

Master Station

- The SCADA Master Station, client or host station/computer, which monitors and controls RTUs and their attached electric apparatus.
- The graphics capabilities of the modern workstations generally results in a human machine interface (HMI) that makes it possible for the operator to easily deal with a variety of systems.

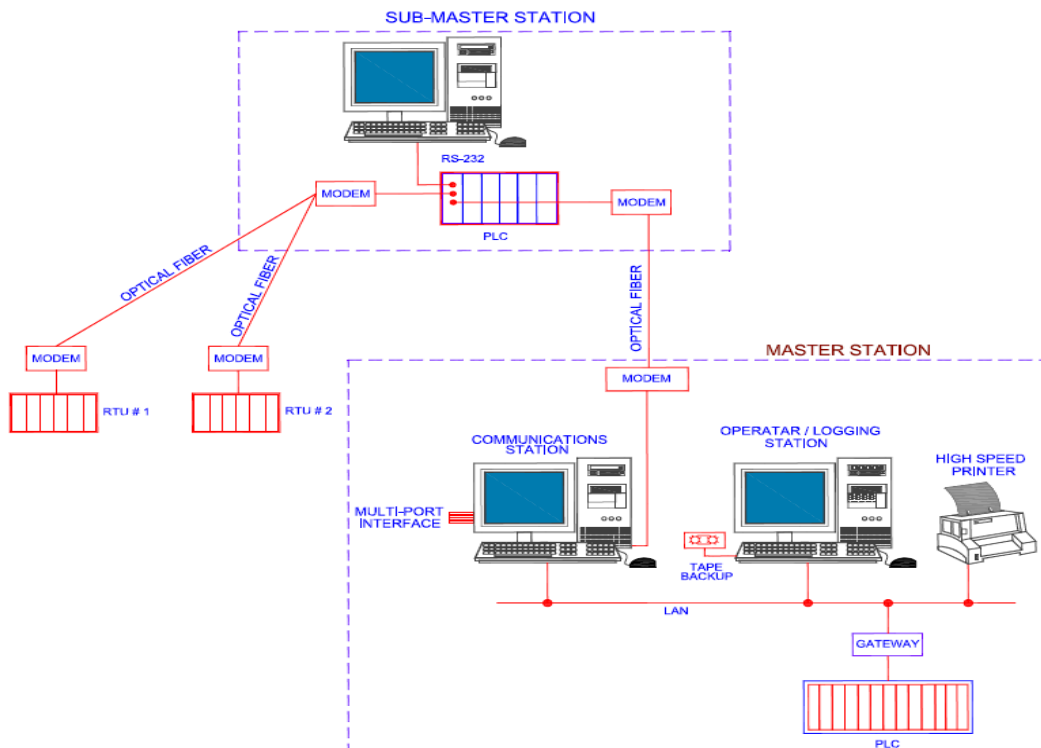

Fig: Typical Structure of Master Station

Communication Medium:

Medium	Limitation
Power Line Carrier	Too slow (about 80 b/s max) needs intact power line High error rate
Radio (broadcast)	One way
Radio (VHF & UHF)	Limited coverage data rate only moderate multipath and shadowing
Telephone (all kinds)	Access delays Limited number of points
Fiber Optic	Terminating Equipment is Costly

The Fiber Optic System is currently preferable to the other media because of the following factors:

- Simplified Installation
- Immunity from EM interference
- Reliability and High Bandwidth
- Availability of Direct Metallic Contacts for devices in the same region
- Two way communication unlike that provided by Radio

Communication Architecture: To connect RTUs or IEDs and master stations, a communications network is required. Seven basic types of networks are defined by IEEE Std 1379-1997. These are following:

1. Point-to-point
2. Multiple point-to-point
3. Multipoint-party line star arrangement
4. Multipoint-party line bus arrangement
5. Multipoint-ring
6. Composite
7. Peer-to-peer communications

Communication Interfaces: RTU can able to communicate via multiple media such as:

- RS-232 / TRS-442 / RS-485
- Optical Fiber
- Ethernet
- Dial up telephone lines / dedicated landlines
- Satellite
- X.25 packet protocols
- Radio via trunked / VHF / UHF /900 MHz

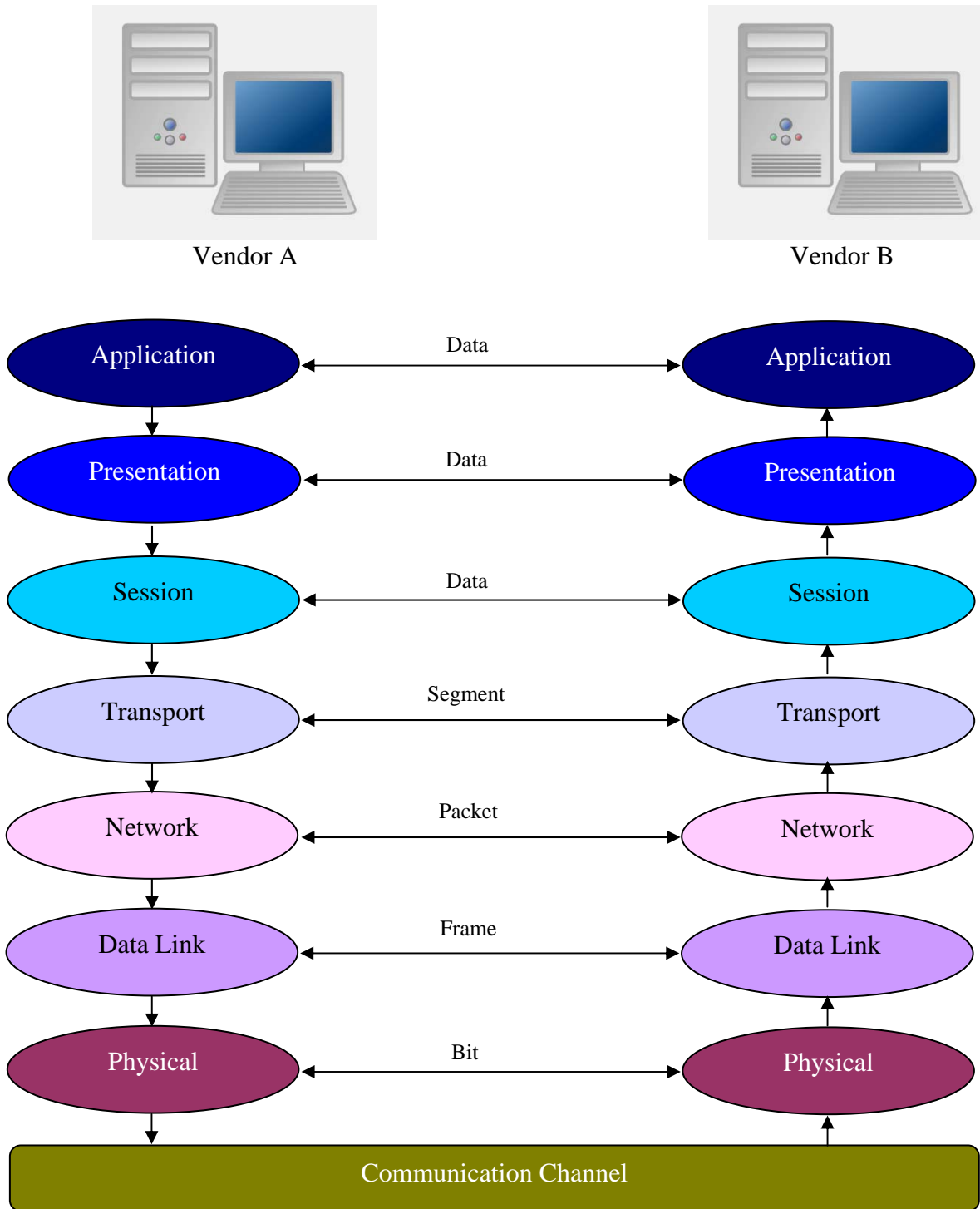
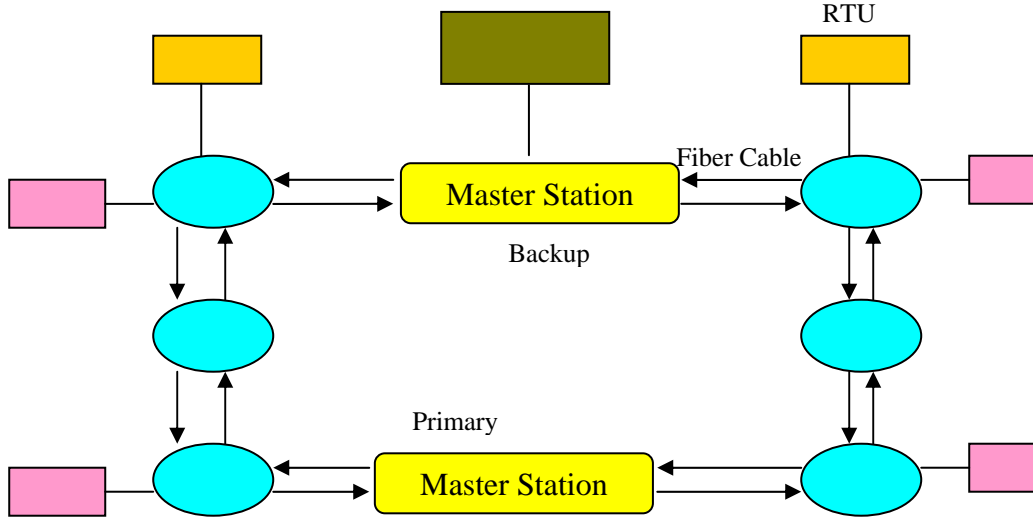

Fig: OSI Network Architecture Seven Layers

Dual redundant fiber loop system:

The Dual Redundancy Loop System involves a Primary SCADA Server and a second one functioning as a Backup. Failure of the primary initiates data shadowing and diagnostic monitoring, leading to the operation of Backup as the SCADA master station.

Figure below shows the optical system as a loop. The loop can be classified as a Logical one rather than a Physical one. The two ends of the loop can be at different substations. This method makes economical use of fiber cable in picking up all the RTUS between two substations.



Advantages

- Break in a fiber cable will not cause a loss of data.
- If a transceiver fails to operate, the other units can be accessed.
- It can be used to bracket the location of faults; this feature is not retained in a radial connection.

Distribution Control Centre (DCC): The Distribution Control Centre consists of Computer system with software for Data Acquisition and applications, storage media for storing the Data, Visual Display Units (VDUs) for displaying the data to the operators and to issue control commands and communication interfaces.

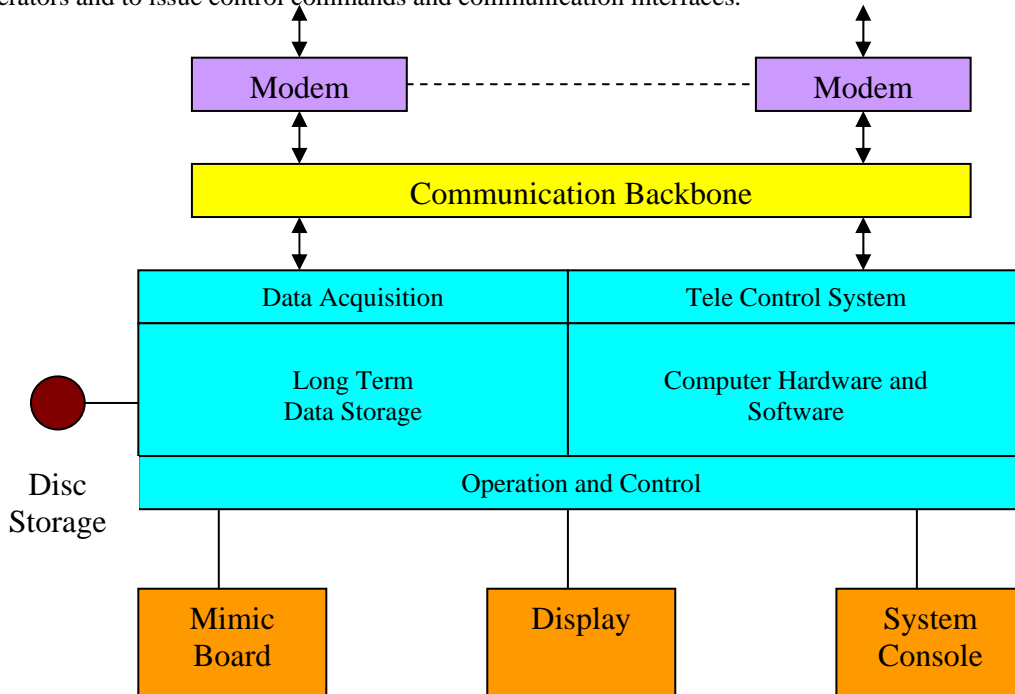

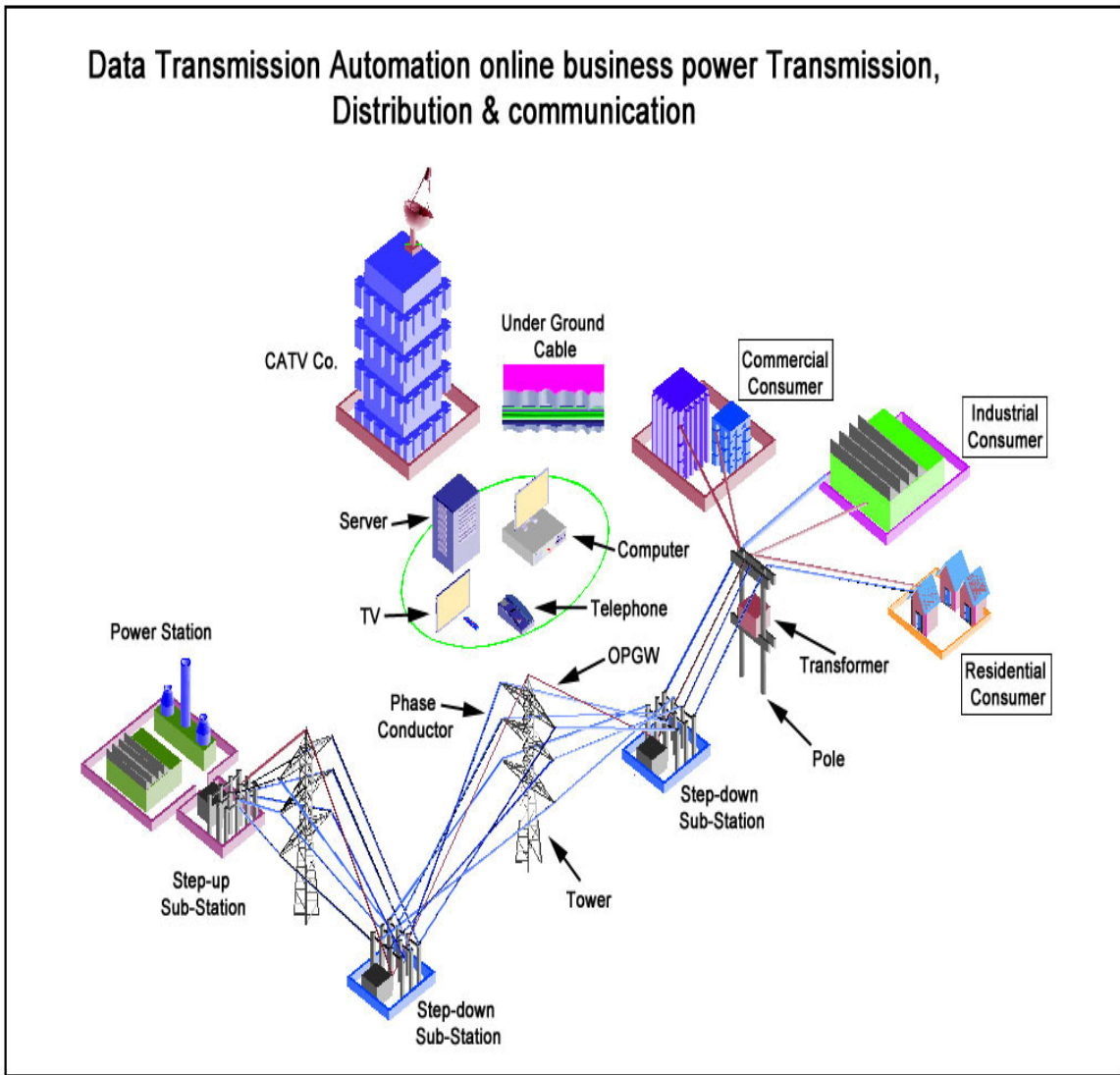

CONCLUSION

SCADA plays an important role in power system supervision and remote control systems. SCADA and IED go hand in hand for greatly enhancing substation automation and reducing human intervention. Power system automation using IED according to IEC61850 and interoperability between relays provides the future trends enclosing in to intelligent and smart grids. On the other hand, the main motivation for accepting the distribution automation in developing countries such as India is to improve operating efficiency of distribution system. This indicates worldwide interest for distribution automation at present. Looking at the interest of power utilities for distribution automation, academic institutions are now taking interest to introduce courses and R & D activities in the field of distribution automation in the regular academic curriculum. The US Stimulus Bill has allocated tens of billions to Smart Grid and Renewable Energy Development. The Indian Government too, recognizing the potential of the Distribution Automation technology is creating a Panel of vendors for the implementation of SCADA/DMS. The value of this project is estimated to be Rs.50, 000 crores.

Development of SCADA/DMS in India

Ministry of Power, Govt of India launched the Restructured Accelerated Power Development & Reforms Programme (R-APDRP) in the XI Five year Plan. The objective of the project is the reduction of Aggregate Technical & Commercial (AT&C) losses in the project areas by 15%. The project has a budget of Rs.50, 000 crores. It consists of the following 2 parts:

1)Part A is the establishment of baseline data and IT applications like Meter Data Acquisition, Meter Reading, Billing, Collections, GIS, MIS, Energy Audit, New Connection, Disconnection, Customer Care Services, Web Self Help Service etc.

2)Part B is renovation, modernization and strengthening of 11kV Substations, Transformer Centers, Re-Conductoring of lines of 11kV level and below, Load Bifurcation, Feeder segregation, Load Balancing, Aerial Bunched Conductoring in thickly populated areas, HVDS etc.

Abbreviations

- DAS- Distribution Automation System
- IDAS-Intelligent Distribution Automation System
- DER-Distributed Energy Resource
- IDER- Intelligent Distribution Energy Resource
- SCADA-Supervisory Control and Data Acquisition System
- DSCADA- Distribution Supervisory Control and Data Acquisition System
- DG-Distribution Generation
- DSM-Demand Side Management
- DMS-Data Management System
- DMS- Distribution Management System
- HMI-Human machine Interface
- MMI-Man Machine Interface
- GUI-Graphical User Interface
- IED-Intelligent Electronic Device
- IUT-Intelligent Universal Transformer
- AMR-Automated Meter Reading
- AGC-Automatic Generation Control
- RTU-Remote Terminal Unit
- FTU-Fault Tolerant Unit
- DNP-Distribution Network Protocol
- FEP-Front End Protocol
- EMS-Energy Management System
- OMS-Order Management System
- MWM-Mobile Work Management
- SWC-Surge Withstand Capability
- DLCC-Dynamic Load Carrying Capacity
- CIS-Communication and Information System
- MDMS-Master Data Multifunctional System
- EEPROM-Electrically Erasable Programmable Read Only Memory
- LBS-Load Break Switch
- WLL-Wire less Local Loop
- SONNET-Synchronous Optical Network
- X.25-Govern Packet (i.e., data) Transmission
- LPP-Locality Preserving Projection
- IVR-Integrated Voice Recognition
- EMS-Expanded Memory Specification
- ERP-Enterprise Resource Planning
- GIS-Graphic Information System
- DCC- Distribution Control centre
- SQL-It is a language used to manipulate and retrieve data

REFERENCES

- [1] S. S. Venkata, A. Pahwa, R. E. Brown, and R. D. Christie, "What Future Distribution Engineers Need to Learn", *IEEE Trans. on Power Systems*, vol. 19, 2004, pp. 17-23.
- [2] D. Bassett, K. Clinard, J. Grainger, S. Purucker, and D. Ward, "Tutorial Course: Distribution Automation", *IEEE Tutorial Publication* 88EH0280-8-PWR, 1988.
- [3] J. B. Bunch, "Guidelines for Evaluating Distribution Automation", *EPRI Report EL-3728*, 1984.
- [4] K. Ghoshal, "Distribution Automation: SCADA Integration is Key", *IEEE Computer Applications in Power*, 1997, pp. 31-35.
- [5] D. Shirmohammadi, W. H. E. Liu, K. C. Lau, and H. W. Hong, "Distribution Automation System with Real-Time Analysis Tools", *IEEE Computer Applications in Power*, 1996, pp. 31-35.
- [6] R. P. Gupta, Sachchidanand, and S. C. Srivastava, "Automated Verses Conventional Distribution System", *Proceedings of the Third International Conference on Power and Energy Systems EuroPES-2003*, Spain, 2003, pp. 33-38.
- [7] M. L. Crow, C. Singh, K. J. Olejniczak, K. Tomsovic, R. Christie, A. Pahwa, and K. Y. Lee, "Integrating Research Results into a Power Engineering Curriculum", *IEEE Trans. on Power Systems*, Vol. 14, No. 2, 1999, pp. 404-411.
- [8] E. K. Chan, and H. Ebenhon, "The Impementation and Evolution of a SCADA System for a Large Distribution Network", *IEEE Transactions on Power systems*, Vol. 7, No. 1, 1992, pp. 320-326.
- [9] J. Carr, "Considerations in the Adoption of a Full Scale Distribution Automation System", *IEEE Transactions on Power Apparatus and Systems*, Vol, PAS-100, No. 3, 1981, pp. 1167-1171.
- [10] R. P. Gupta, and S. C. Srivastava, "Technology Development and Implementation for Power Distribution Automation", *Water and Energy International Journal*, Vol. 61, No. 4, 2004, pp. 40-47.

- [11] D. L. Brown, J. W. Skeen, P. Daryani, and F. A. Rahimi, "Prospects for Distribution Automation at Pacific Gas & Electric Company", *IEEE Transactions on Power Delivery*, vol. 6, No. 4, 1991, pp. 1946-1954.
- [12] W. R. Cassel, "Distribution Management Systems: Functions and Payback", *IEEE Transactions on Power Systems*, Vol. 8, No. 3, 1992, pp. 796-801.
- [13] G. M. Burt, J. R. McDonald, A. G. King, J. Spiller, D. Brooke, and R. Samwell, Intelligent On-Line Decision Support for Distribution System Control and Operation, *IEEE Transactions on Power Systems*, Vol. 10, No. 4, pp. 1995, 1820-1827.
- [14] D. G. Hart, D. Uy, J. Northcote-Green, C. LaPlace, and D. Novosel, "Automated Solutions for Distribution Feeders", *IEEE Computer Applications in Power*, 2000, pp. 25-30.
- [15] A. Pahwa and J. K. Shultis, "Assessment of the Present Status of Distribution Automation", Engg. Experiment Station, Kansas State Univ., Manhattan, KS, Rep. 238, 1992.
- [16] S. S. Venkata and A. Pahwa, "Including Distribution Automation in An Undergraduate Course", *Proceedings of the workshop on Teaching of First Course in Power Systems*, Florida, February 11-13, 2005, available at http://www.ece.umn.edu/groups/power/workshop_feb05/NSFWorkshop_Orlando_2005_Program_Registration.html

Bibliographies



Mr. Santosh Kumar Singh passed Electrical Engineering from WBUT in 2009. He is a member of IET,UK. He was a participant of student pavilion of Elecrama-2008 with a project on Harmonics. His area of research is on power system quality like harmonics, transient stability, power automation using SCADA and optical fiber system. Right now he is working in the R&D department of Supreme & Co. kolkata, India.



Mr. Dharmbir Prasad passed Electrical Engineering from WBUT in 2009. He is a member of IET,UK. He was a participant of student pavilion of Elecrama-2008 with a project on Harmonics. His area of research is on power system quality like harmonics, transient stability, power automation using SCADA and optical fiber system. Right now he is working in the R&D department of Supreme & Co. kolkata, India..



Mr. Gautam Agarwal is a student of fourth year Electrical Engineering of Visvesvaraya University Bangalore and he is a trainee of Supreme & Co., his area of research is on power system automation.

We are thankful to Mr. Harish Agarwal, CEO of Supreme & Co. for his support in making the paper. We are also thankful to Mr. R.K Gupta the technical and marketing advisor, Mr. Suman Chatterjee the design engineer of Supreme and company & Mr. Arnab Dutta the graphics designer of Supreme & Co.

Email us at- engineeringteam@supreme.in